

See discussions, stats, and author profiles for this publication at: <https://www.researchgate.net/publication/275350046>

# Streptomyces flavomacrosporus, A multi-metal tolerant potential bioremediation candidate isolated from paddy field...

Article · March 2015

CITATIONS

5

READS

94

8 authors, including:



**Channarayapatna-Ramesh Sunil Kumar**

MMK & SDM Mahila Mahavidyala, Mysuru

6 PUBLICATIONS 8 CITATIONS

SEE PROFILE



**Bhavya G.**

University of Mysore

3 PUBLICATIONS 5 CITATIONS

SEE PROFILE



**Ramachandra Kini**

University of Mysore

510 PUBLICATIONS 10,589 CITATIONS

SEE PROFILE



**Dr. Geetha N**

University of Mysore

41 PUBLICATIONS 292 CITATIONS

SEE PROFILE

Some of the authors of this publication are also working on these related projects:



Structure-function relationship and action mechanism of krait natriuretic peptide [View project](#)



Scaling of heavy metals bio-recovery process by multi-metal tolerant bacteria [View project](#)

## RESEARCH ARTICLE

## “*Streptomyces flavomacrosporus*, A multi-metal tolerant potential bioremediation candidate isolated from paddy field irrigated with industrial effluents”

Sunil KCR, Swati K, Bhavya G, Nandhini M, Veedashree M, Prakash HS, Kini KR, and Geetha N\*

Eco-Biotech Laboratory, Department of Studies in Biotechnology, Manasagangotri, University of Mysore, Mysuru, India – 570 006

\*Corresponding author E-mail : [geetha@appbot.uni-mysore.ac.in](mailto:geetha@appbot.uni-mysore.ac.in)

Manuscript details:	ABSTRACT
<p>Received: 04 January, 2015 Revised : 20 February, 2015 Accepted: 28 February, 2015 Published : 30 March, 2015</p> <p><b>Editor: Dr. Arvind Chavhan</b></p> <p><b>Cite this article as:</b> Sunil KCR, Swati K, Bhavya G, Nandhini M, Veedashree M, Prakash HS, Kini KR, and Geetha N (2015) “<i>Streptomyces flavomacrosporus</i>, A multi-metal tolerant potential bioremediation candidate isolated from paddy field irrigated with industrial effluents” <i>Int. J. of Life Sciences</i>, 3(1): 9- 15.</p> <p><b>Acknowledgements:</b> Authors were thankful to University grant commission, New Delhi, for financial assistance.</p> <p><b>Copyright:</b> © 2015   Author(s), This is an open access article under the terms of the Creative Commons Attribution-Non-Commercial - No Derivs License, which permits use and distribution in any medium, provided the original work is properly cited, the use is non-commercial and no modifications or adaptations are made.</p>	<p>Prime drive of the research work carried out was to explore heavy metal-tolerant bacteria from rhizospheric soil samples collected from contaminated agricultural lands of southern India. Soil samples of Mysore agricultural lands of Karnataka state, India, irrigated with industrial effluents from several decades, were brought to the laboratory in sterile polythene bags and were screened by plating serially diluted samples on to Minimal Glucose Yeast extract agar media amended with 0.3mM mercury. Morphologically differing cultures were tested for their tolerance to mercury by growing them in the liquid minimal media amended with 0.3, 0.4, 0.5 and 0.6mM concentrations of mercuric chloride and 0.5, 1.0 and 1.5mM of lead nitrate at optimal physiological conditions. Further the isolates were identified using 16s r-DNA PCR amplification. Blast analysis of the sequence results revealed for the first time the tolerance potential of <i>Streptomyces flavomacrosporus</i>, <i>Bacillus methylotrophicus</i>, <i>Achromobacter xylosoxidans</i>, <i>Bacillus tequilensis</i>, <i>Bacillus pumilus</i>, and <i>Bacillus subtilis</i> and their chances of participation in bioremediation of mercury. Among these isolates the actinomycetes <i>S. flavomacrosporus</i>, showed tolerance to multi metals.</p> <p><b>Keywords-</b> Heavy Metals, Minimal Glucose Yeast Extract (MGY), Industrial effluents, Agricultural lands, Metal-tolerant bacteria.</p>
	<h3>INTRODUCTION</h3> <p>To meet dietary needs of growing global population, due to shortage of natural resources, waste water, industrial effluents and municipal sewage wastes are using as sources of irrigation in most of the countries, including India; which enhances the concentration of heavy</p>

metals in soil and aid transportation of metal into the food chain. Industrial effluents containing heavy metals discharged into streams may pose high toxicity risks to aquatic organisms and to human health. Therefore, it is important to understand how to change the amount of effluents with heavy metals discharged from industries into open aquatic ecosystems both for effective management of heavy metals and to foster sustainable ecosystems (Kwon *et al.*, 2014). Naturally occurring hazardous metal mercury exist on earth crust by various anthropogenic means like metal smelting, industrial production and natural means like erosion, volcanic eruptions etc., (Tchounwou *et al.*, 2003). Mercury is unique because of the combination of the extreme toxicity. It is a metal with no known biological function and low vapor pressure of elemental mercury, which is a liquid at room temperature. In contrast, most other heavy metals are needed by the cell, either as cofactors of enzymes or as electron acceptors for anaerobic respiration (Wagner-Döbler, 2003). Lead (Pb) an extremely stable element, toxic to most of the living forms, as discussed in many scientific literatures lead emission of due to anthropogenic means is 100 times higher than natural emission. Lead poisoning retain as a major source for pediatric health problems in India. (Patel *et al.*, 2006). However, existence of lead in top soil is by various anthropogenic means like mining, smelting, recycling of sewage sludge and motor vehicle exhausts. By these various anthropogenic phenomenon, level of Pb is significantly enhanced in surface soil (Reeder and Shapiro, 2003).

Expensive physico-chemical techniques were unsuitable for treatment of bulk effluents with complexing organic and metal contaminations (Malik, 2004). Wide range of aquatic and terrestrial contamination by various anthropogenic means needs special attention from researchers towards developing sustainable biological tool for the promotion and development of better environmental management. (Juwarkar *et al.*, 2010). It is necessary to understand survivability of microbes in contaminated site to understand metabolic capability of native microbes towards utilizing native resources (Ilyina *et al.*, 2003). Diverged properties processed by microbes while interacting against metal ions like metal speciation, toxicity, mobility and mineral dissolution entertained most of the researchers to study interaction of microbial community in contaminated site (Gadd, 2013). This open up to develop clean-up strategies by

isolating metal resistant microbes, which is a simple environmental friendly and cost effective and alternative to current treatment technologies (Wagner-Döbler, 2003). It is know that ability of metal tolerance were greatly influenced by the environmental conditions, study of metal-microbe interactions by various extra cellular and intra cellular phenomena will aid scientific community to develop effective clean-up strategies (Gadd and Griffiths, 1977). With this background present work was primely focused on screening of potent bioremediation candidate from the soil samples which can contribute for removal of pollutants by building suitable research strategy in the future work.

## MATERIALS AND METHODS

### Collection of samples

Soil samples were collected in the mid 2013 from agriculture lands of suburban Mysore, Karnataka state, India, irrigated with industrial effluents. Rhizospheric soil samples were collected from the depth of 0.5-1feet from different location (Fig 1) of the sampling site. Samples were collected in sterile polythene bags and brought to the laboratory for further studies.



**Fig. 1: Google earth image showing GPRS location of sampling site in suburban area of Mysuru district.**

### Isolation of bacteria tolerant to multi-metals

25 g soil samples were serially diluted with 225 mL of 0.9% saline, and six-fold dilutions were plated on to MGY agar (minimal media) (Zhu et al. 2012)

supplemented with 0.3 millimolar concentration of mercuric chloride and MGY agar without mercuric chloride as a control and incubated at 37° C for 48 hours and experiments conducted in triplicates.

#### **Morphological and biochemical characterization of metal tolerant bacteria**

Gram staining was carried out according to the protocol (Vincent 1970). Results were confirmed by KOH solubility test, also ability of isolates for the production of gelatinase enzyme was performed according to (James and Sherman 1987).

#### **Physiological characterization of metal tolerant isolate**

##### **Determination of optimum temperature**

The temperature at which the cultures had their maximum growth was considered the optimum temperature. The optimum temperature for each isolates was determined by inoculating them on LB broth at different temperatures like 25°C, 35°C, 37°C and 40°C in (New Brunswick™ Innova, USA) at 100rpm, growth rate was measured against turbidity of the medium till 96 hours with 24 hours of time intervals at 600nm using UV spectrophotometer (Beckman coulter DU 700, Germany).

##### **Determination of optimum pH**

Optimum pH of metal tolerant isolates was done by growing cultures at different pH conditions, isolates were inoculated against pH 4, 7, 9 and 12. And incubated at their optimal temperature (New Brunswick™ Innova, USA) at 100rpm, growth rate was measured against turbidity of the medium till 96 hours with 24 hours of time intervals at 600nm using UV spectrophotometer (Beckman coulter DU 700, Germany).

##### **Determination of minimum inhibitory concentration against mercuric chloride**

Cultures were inoculated on MGY media amended with mercuric chloride at different concentrations like 0.3, 0.4, 0.5 and 0.6 mM and incubated at optimal conditions, growth rate was measured against turbidity of the medium till 96 hours with 24 hours' time interval by at 600nm using UV spectrophotometer (Beckman coulter DU 700, Germany).

##### **Determination of minimum inhibitory concentration against lead nitrate**

Isolates grown in Lead nitrate amended in MGY media at different concentrations of 0.5, 1.0 and 1.5 mM were measured to record growth rate at 600nm, using UV spectrophotometer (Beckman coulter DU 700, Germany). After a day of incubation at optimal physiological conditions.

##### **Molecular characterization of metal-tolerant bacterial isolates**

##### **DNA isolation**

Genomic DNA was isolated by using altered protocol of Doyel and Doyel's method. Five-day-old bacterial cultures grown in LB broth at 35°C were transferred to 2 ml micro-centrifuge tube and centrifuged at 10000 rpm for 15 min, supernatant was discarded and the pellets were treated with 500µl of extraction buffer with the composition of 100mM Tris, 20mM EDTA, 500mM NaCl and 5% SDS, and incubated for 30min at 65°C. The solution with chloroform and isopropanol was mixed with the ratio of 24:1 till the solution forms slurry. This milky white solution was centrifuged at 12,000 rpm for 10 min. aqueous layer was transferred to sterilized eppendroff and equal volume of chloroform: Isopropanol was added and centrifuged at 12000 rpm to pellet out DNA for about 10 min. To the transferred aqueous solution 1/10<sup>th</sup> volume of sodium acetate was added and incubated at -20°C for 60 min, after the incubation period it was centrifuged at 12000 rpm for 10 min, the pellets were washed with 70% ethanol which was air-dried and dissolved in 20-40µl of elution buffer and stored at -20°C (Doyle 1991).

##### **PCR amplification of 16s rDNA**

Total DNA from 13 samples were used as template to amplify variable region of bacterial 16s rDNA by PCR using the universal primers 16sF 5'-CCAGACTCTACGGGAGGCAGC-3' and 16sR 5'-GCTGACGAGAGCCATGCAGCACC-3' (Sigma Aldrich). The PCR reaction system of 50µl included 5µl of 10x Taq buffer, 1 µl of 0.2mM dNTPs, 0.15µl of forward and reverse primers (10pmol), 10 µl of DNA dilution 100ng/ µl, 1.75 µl of Taq polymerase (1U) and 37.45µl of nuclease free water and the system was programmed with 30 cycles at 94°C for 4 mins, 94°C for 45secs, 55°C for 45secs, 72°C for 1min and 74°C for 10mins (Bio Rad). The results were analyzed by 1.2% agarose gel electrophoresis.

**nBlast analysis of nucleotide sequence**

All sequences were identified using NCBI nucleotide blast as the selected algorithm, except highly somewhat similar sequences algorithm was chosen to identify the sequence and the Mercury-tolerant bacterial isolates was identified.

**Phylogenetic analysis**

A phylogenetic tree was constructed based on the aligned sequence of partial 16s rDNA region. Evolutionary analyses were conducted in LIRMM by using Neighbour-Joining (NJ) and Maximum Parsimony (MP) analysis.

**RESULTS AND DISCUSSION**

Remediation of Alaska coastal line which was contaminated with oil spill of Exxon Valdez in 1989 using bioremediation tools gained the public attention. Most importantly activity of bacteria relies on ability and availability of residual organic materials to serve as energy sources, it is strongly dependent on nature of contamination in the site. Site-specific bioavailability influences bioremediation process positively towards developing effective clean-up strategies (Boopathy, 2000).

**Table1- Biochemical characteristics of Mercury tolerant bacteria**

Isolates Code	Name of the isolate	Gram's test	KOH solubility test	Gelatin hydrolysis test
UOMGSP001	<i>Bacillus tequilensis</i>	+	-	+
UOMGSP002	<i>Achromobacter xylosoxidans</i>	-	+	+
UOMGSP003	<i>Bacillus pumilus</i>	+	-	-
UOMGSP005	<i>Bacillus methylotrophicus</i>	+	-	+
UOMGSP008	<i>Streptomyces flavomacrosporus</i>	+	-	-
UOMGSP009	<i>Bacillus subtilis</i>	+	-	+

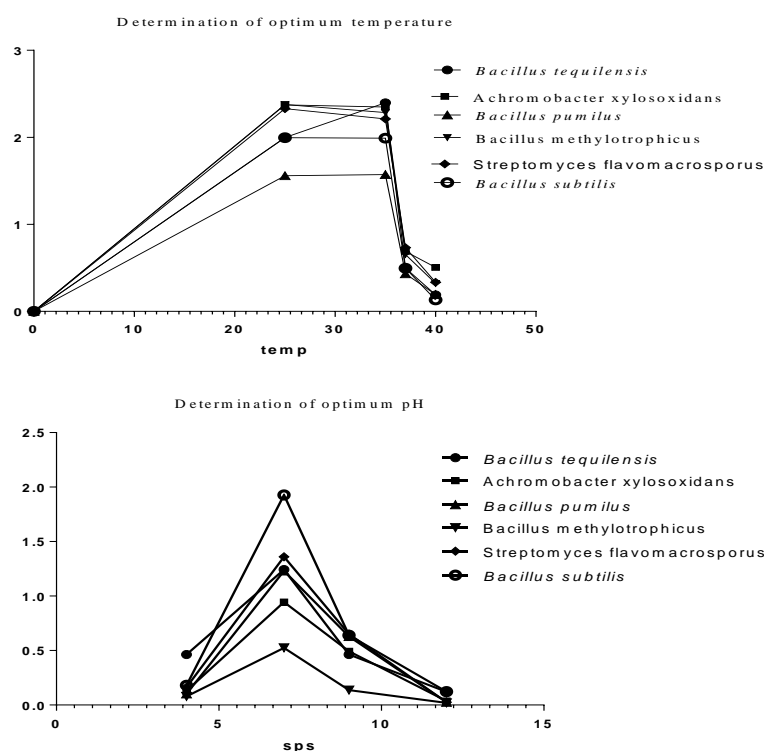

**Fig. 2: Physiological characterization of metal tolerant isolate. Determination of optimum physiological conditions of selected mercury resistant isolates**

It is known that rhizospheric microbes play a major role in altering physico-chemical characteristics of its surrounding environment, which possess impact on biogeochemical mobility of metals and associated elements (Gadd, 2010).

Our experimental studies on evaluating metals tolerance ability of bacterial isolates isolated from rhizospheric soil samples from the agro-climatic regions of southern Karnataka irrigated with industrial effluents enabled us to isolate twelve bacterial isolates tolerant to mercury and lead, among the twelve isolates *Bacillus methylotrophicus*, *Streptomyces flavomacrosporus*, *Bacillus subtilis*, *Bacillus pumilus*, *Bacillus tequilensis* which were positive to gram's reaction and *Achromobacter xylosoxidans* which

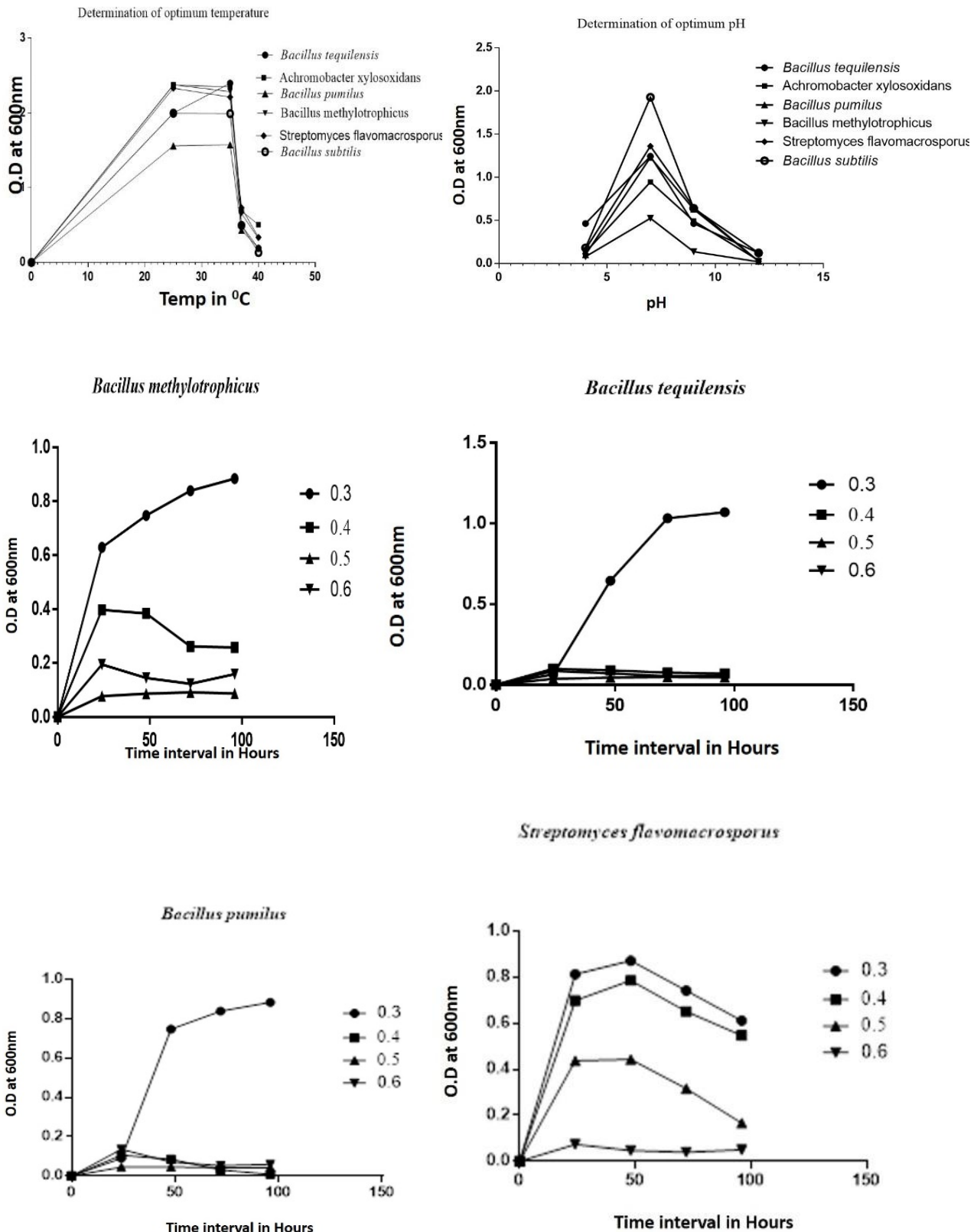

Fig. 3: Determination of MIC of heavy metal salt mercuric chloride against mercury tolerant isolates

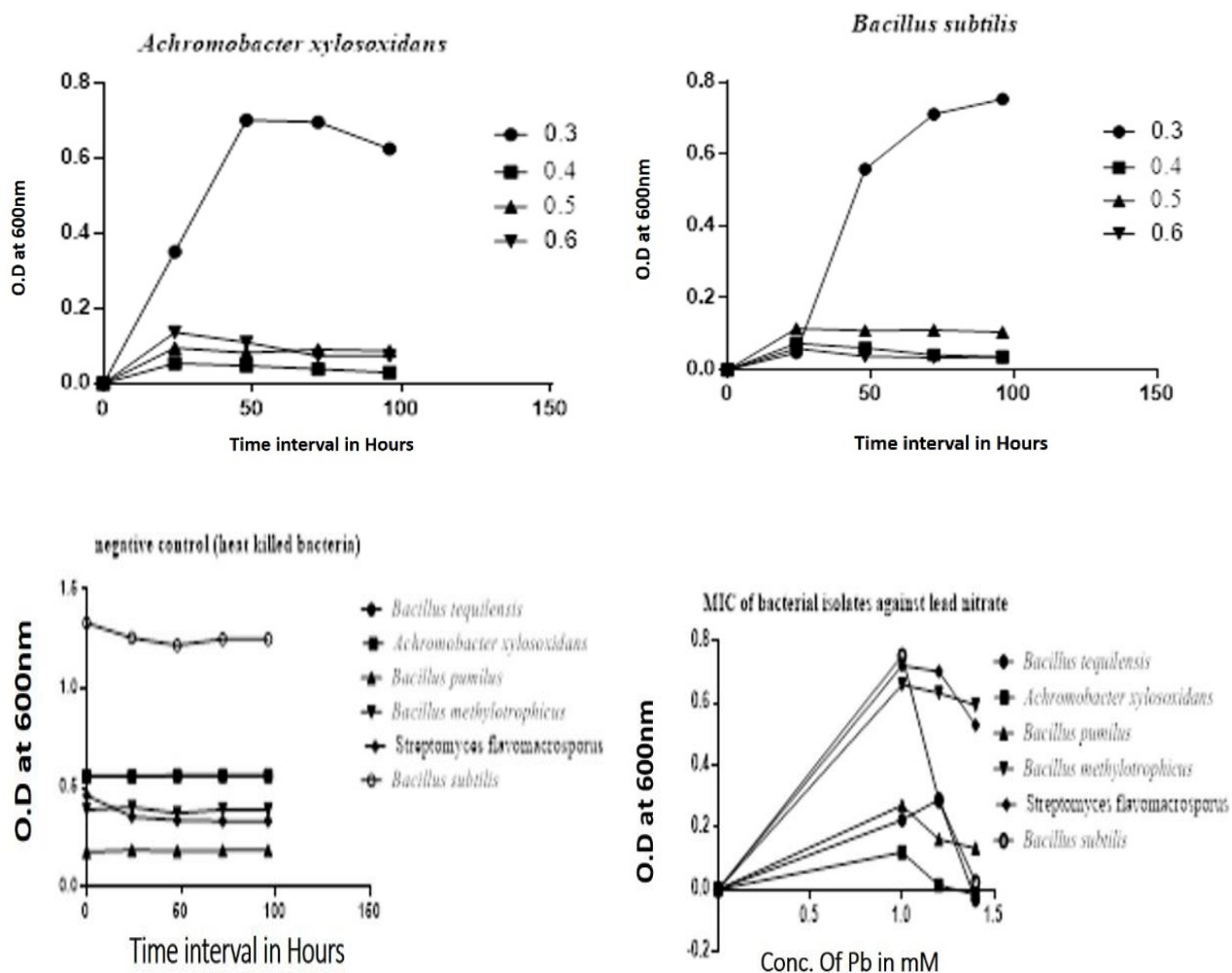

Fig. 4: Determination of MIC of heavy metal salt mercuric chloride against mercury tolerant isolates

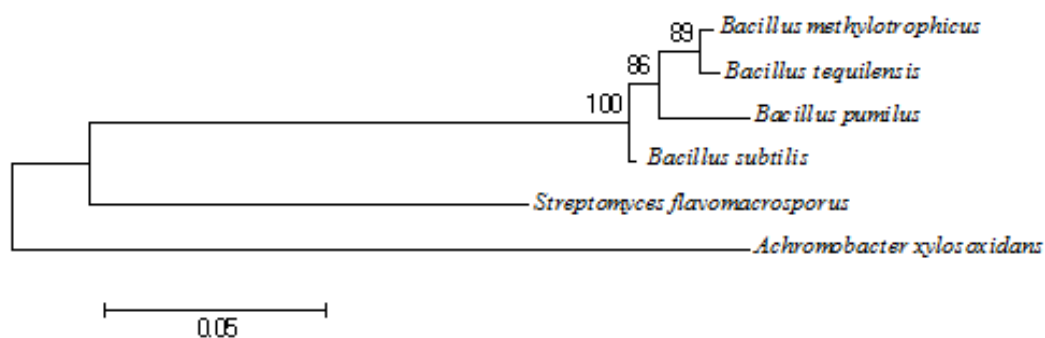

Fig. 5 : Phylogenetic analysis

is negative to gram's reaction. All the selected six isolates were grown at optimal pH 7 and optimal temperature 25°C also shown to be grown equally even at 45°C by exhibiting thermostatic nature, isolates were chosen based on their comparatively higher growth competence and enhanced tolerance for

mercury at 0.3, 0.4, 0.5 and 0.6 mM and lead at 0.5, 1.0 and 1.5mM conc. *Bacillus tequilensis*, *Bacillus pumilus*, *Achromobacter xylosoxidans* and *Bacillus subtilis* were exhibited higher growth at the concentration of 0.3mM of mercuric chloride concentration after 24 hours and no significant growth were recorded at the higher

concentrations like 0.4, 0.5 and 0.6 mM concentrations respectively. When these isolates were subjected to determine their concentration for minimal inhibition against lead nitrate it is recorded that *Bacillus tequilensis*, *Bacillus Pumilus* and *Achromobacter xylosoxidans* grown at moderate level not exhibited much resistant at any of the treated concentrations. But isolate *Bacillus subtilis* showed its maximal growth capacity at both the concentration of 0.5 and 1.0mM of lead nitrate.

Isolates like *Bacillus methylotrophicus* and *Streptomyces flavomacrosporus* shown to be higher growth competence with respect to all other selected candidates when it is subjected to study their MIC against mercuric chloride at the concentration of 0.3, 0.4, and 0.5mM conc. At fair growth was recorded at 0.6mM conc. and constant growth was recorded even at the concentration of 0.5, 1.0 and 1.5mM of lead nitrate, with respect to *Streptomyces flavomacrosporus* and *Bacillus methylotrophicus* shown to be a good bioremediation candidate by exhibiting its higher growth rate even at 0.3, 0.4 and 0.5mM conc. and lowest growth rate at the conc. 0.6mM with respect to MIC test against mercuric chloride. It has also revealed its capacity to grow at all the test concentrations of lead nitrate of 0.5, 1.0 and 1.5mM of lead nitrate. With results it is concluded that these bacterial isolates may have potential implication cleaving up of detoxifying mercury and lead contaminated sites in the future. Therefore, based on the physiological, biochemical and molecular characterization results, the study reports *Streptomyces flavomacrosporus* for the first exhibiting tolerance to toxic heavy metal Mercury and lead.

## CONCLUSION

Though there are several potential metal tolerant bacteria isolated across, it is necessarily important to design the clean strategy with the native species. There is much debate over whether to use natural or genetically engineered microbes in bioremediation. The advantages of naturally-occurring microbes currently outweigh those of GEMs (Boopathy, 2000)

## REFERENCES

- Boopathy R (2000) Factors limiting bioremediation technologies. *Bioresource technology* 74 (1):63-67
- Doyle J (1991) DNA protocols for plants. In: *Molecular techniques in taxonomy*. Springer, pp 283-293
- Gadd GM (2010) Metals, minerals and microbes: geomicrobiology and bioremediation. *Microbiology* 156 (3):609-643
- Gadd GM (2013) Microbial Roles in Mineral Transformations and Metal Cycling in the Earth's Critical Zone. In: *Molecular Environmental Soil Science*. Springer, pp 115-165
- Gadd GM, Griffiths AJ (1977) Microorganisms and heavy metal toxicity. *Microbial Ecology* 4 (4):303-317
- Ilyina A, Castillo Sanchez M, Villarreal Sanchez J, Ramirez Esquivel G, Candelas Ramirez J (2003) Isolation of soil bacteria for bioremediation of hydrocarbon contamination. *Vestnik Moskovskogo Universiteta Seriya 2*:88-91
- James GC, Sherman N (1987) *Microbiology: A laboratory manual*. Benjamin Publishing Co. Inc., California,
- Juwarkar AA, Singh SK, Mudhoo A (2010) A comprehensive overview of elements in bioremediation. *Reviews in Environmental Science and Bio/Technology* 9 (3):215-288
- Kwon YS, Bae MJ, Park YS (2014) Changes of Heavy Metals in Pollutant Release and Transfer Registers (PRTRs) in Korea. *International journal of environmental research and public health* 11 (3):2381-2394
- Malik A (2004) Metal bioremediation through growing cells. *Environment international* 30 (2):261-278
- Patel K, Shrivastava K, Hoffmann P, Jakubowski N (2006) A survey of lead pollution in Chhattisgarh State, central India. *Environmental geochemistry and health* 28 (1-2):11-17
- Reeder P, Shapiro L (2003) Lead contamination of soils in Belize City, Belize, Central America. *Journal of Environmental Science and Health, Part A* 38 (12):2785-2805
- Tchounwou PB, Ayensu WK, Ninashvili N, Sutton D (2003) Review: Environmental exposure to mercury and its toxicopathologic implications for public health. *Environmental Toxicology* 18 (3):149-175
- Vincent JM (1970) A manual for the practical study of the root-nodule bacteria. A manual for the practical study of the root-nodule bacteria
- Wagner-Döbler I (2003) Pilot plant for bioremediation of mercury-containing industrial wastewater. *Applied microbiology and biotechnology* 62 (2-3):124-133
- Zhu H, Guo J, Chen M, Feng G, Yao Q (2012) *Burkholderia dabaoshanensis* sp. nov., a heavy-metal-tolerant bacteria isolated from Dabaoshan mining area soil in China. *PloS one* 7 (12):e50225.